

## Sample Multiple-Choice Questions

**Part A Directions:** Each of the questions or incomplete statements below is followed by four suggested answers or completions. Select the answer that is best in each case. When you have completed part A, you should continue on to part B.

1. By discharging electric sparks into a laboratory chamber atmosphere that consisted of water vapor, hydrogen gas, methane, and ammonia, Stanley Miller obtained data that showed that a number of organic molecules, including many amino acids, could be synthesized. Miller was attempting to model early Earth conditions as understood in the 1950s. The results of Miller's experiments best support which of the following hypotheses?
  - (A) The molecules essential to life today did not exist at the time Earth was first formed.
  - (B) The molecules essential to life today could not have been carried to the primordial Earth by a comet or meteorite.
  - (C) The molecules essential to life today could have formed under early Earth conditions.
  - (D) The molecules essential to life today were initially self-replicating proteins that were synthesized approximately four billion years ago.

<b>Essential Knowledge</b>	1.D.1: There are several hypotheses about the natural origin of life on Earth, each with supporting scientific evidence.
<b>Science Practice</b>	3.3: The student can evaluate scientific questions.
<b>Learning Objective</b>	1.28: The student is able to evaluate scientific questions based on hypotheses about the origin of life on Earth.

2. Simple cuboidal epithelial cells line the ducts of certain human exocrine glands. Various materials are transported into or out of the cells by diffusion. (The formula for the surface area of a cube is  $6 \times S^2$ , and the formula for the volume of a cube is  $S^3$ , where  $S$  = the length of a side of the cube.)

Which of the following cube-shaped cells would be most efficient in removing waste by diffusion?

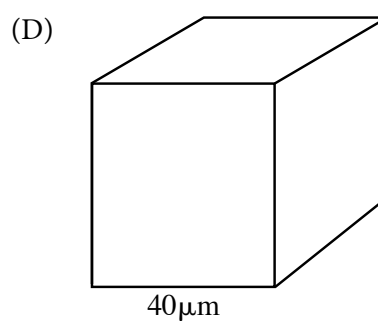
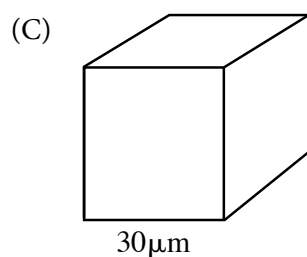
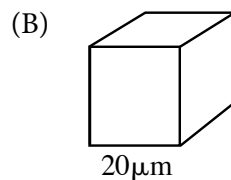
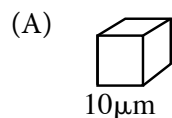

<b>Essential Knowledge</b>	2.A.3: Organisms must exchange matter with the environment to grow, reproduce, and maintain organization.
<b>Science Practice</b>	2.2: The student can apply mathematical routines to quantities that describe natural phenomena.
<b>Learning Objective</b>	2.6: The student is able to use calculated surface area-to-volume ratios to predict which cell(s) might eliminate wastes or procure nutrients faster by diffusion.

3. When DNA replicates, each strand of the original DNA molecule is used as a template for the synthesis of a second, complementary strand. Which of the following figures most accurately illustrates enzyme-mediated synthesis of new DNA at a replication fork?

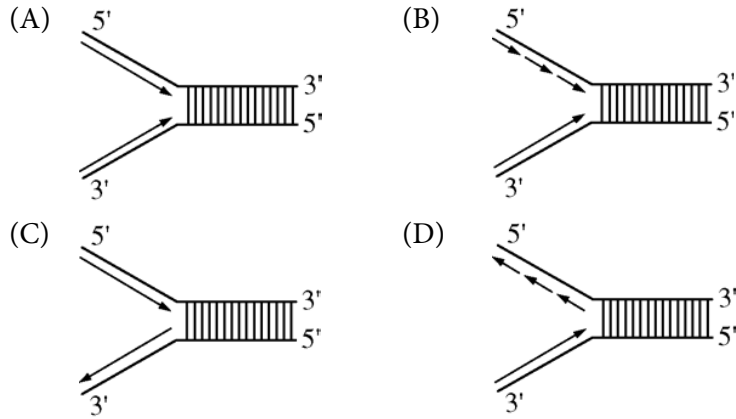

<b>Essential Knowledge</b>	3.A.1: DNA, and in some cases RNA, is the primary source of heritable information.
<b>Science Practice</b>	1.2: The student can describe representations and models of natural or man-made phenomena and systems in the domain.
<b>Learning Objective</b>	3.3: The student is able to describe representations and models that illustrate how genetic information is copied for transmission between generations.

4. The following is a food web for a meadow habitat that occupies 25.6 km<sup>2</sup>. The primary producers' biomass is uniformly distributed throughout the habitat and totals 1,500 kg/km<sup>2</sup>.

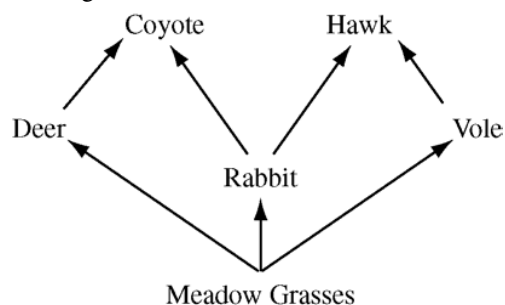

Developers have approved a project that will permanently reduce the primary producers' biomass by 50 percent and remove all rabbits and deer.

Which of the following is the most likely result at the completion of the project?

- (A) The biomass of coyotes will be 6 kg, and the biomass of hawks will be 0.5 kg.
- (B) The biomass of coyotes will be dramatically reduced.
- (C) The coyotes will switch prey preferences and outcompete the hawks.
- (D) There will be 50 percent fewer voles and 90 percent fewer hawks.

<b>Essential Knowledge</b>	4.A.6: Interactions among living systems and with their environment result in the movement of matter and energy.
<b>Science Practice</b>	1.4: The student can use representations and models to analyze situations or solve problems qualitatively and quantitatively.
<b>Learning Objective</b>	4.15: The student is able to use visual representations to analyze situations or solve problems qualitatively to illustrate how interactions among living systems and with their environment result in the movement of matter and energy.

5. A pathogenic bacterium has been engulfed by a phagocytic cell as part of the nonspecific (innate) immune response. Which of the following illustrations best represents the response?

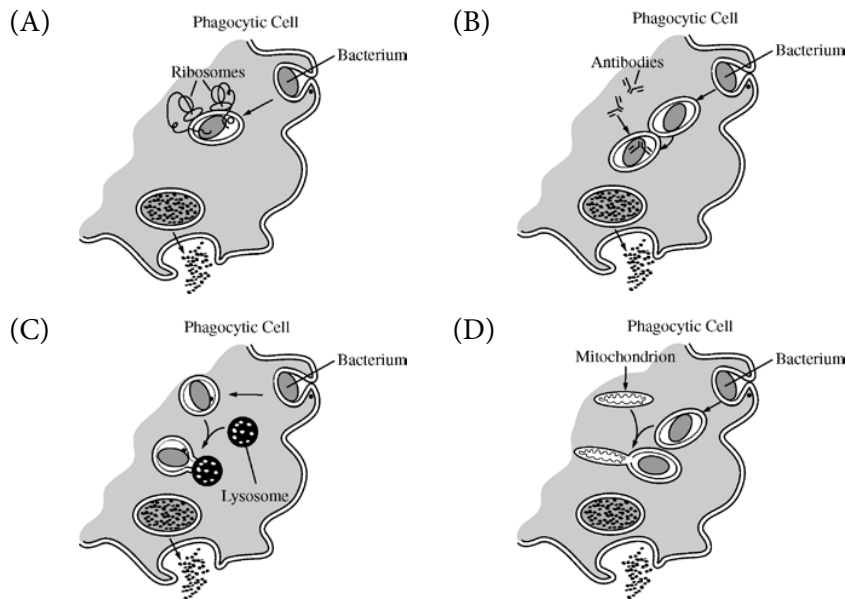

<b>Essential Knowledge</b>	2.D.4: Plants and animals have a variety of chemical defenses against infections that affect dynamic homeostasis.
<b>Science Practice</b>	1.2: The student can describe representations and models of natural or man-made phenomena and systems in the domain.
<b>Learning Objective</b>	2.29: The student can create representations and models to describe immune responses.

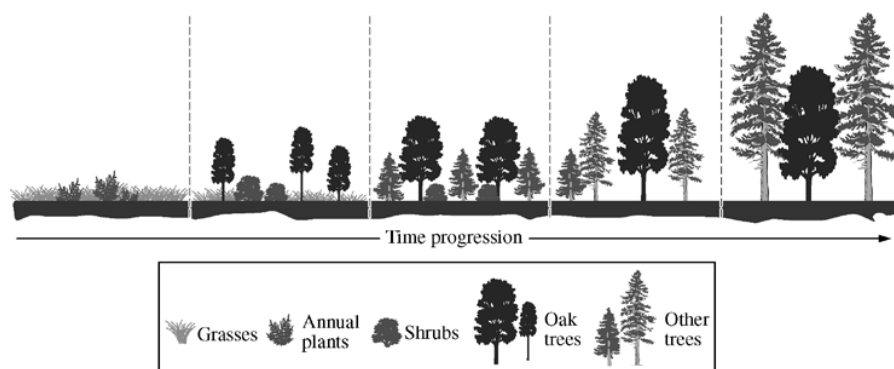

6. The diagram above shows the progression of ecological events after a fire in a particular ecosystem. Based on the diagram, which of the following best explains why the oak trees are later replaced by other trees?
- (A) Eventually the other trees grow taller than the oak trees and form a dense canopy that shades the understory.
  - (B) Oak trees alter the pH of the soil, making the forest better suited for shrubs and other trees.
  - (C) Roots of shrubs proliferate in the soil of the forest and prevent the oak trees from obtaining water.
  - (D) Oak trees succumb to environmental pollutants more readily than do either the shrubs or the other trees.

<b>Essential Knowledge</b>	4.C.4: Diversity of species within an ecosystem may influence the stability of the ecosystem.
<b>Science Practice</b>	6.4: The student can make claims and predictions about natural phenomena based on scientific theories and models.
<b>Learning Objective</b>	4.27: The student is able to make scientific claims and predictions about how species diversity within an ecosystem influences ecosystem stability.

7. Lactose digestion in *E. coli* begins with its hydrolysis by the enzyme  $\beta$ -galactosidase. The gene encoding  $\beta$ -galactosidase, *lacZ*, is part of a coordinately regulated operon containing other genes required for lactose utilization.

Which of the following figures correctly depicts the interactions at the *lac* operon when lactose is NOT being utilized? (The legend below defines the shapes of the molecules illustrated in the options.)

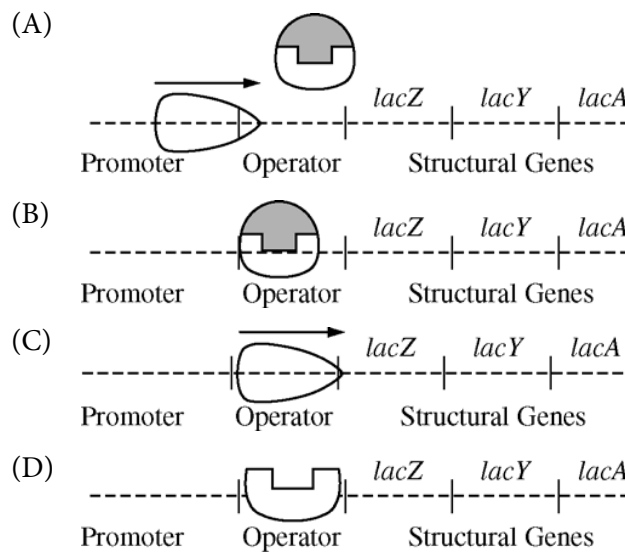
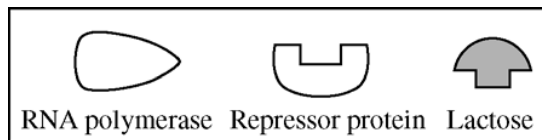

<b>Essential Knowledge</b>	3.B.1: Gene regulation results in differential gene expression, leading to cell specialization.
<b>Science Practice</b>	1.4: The student can use representations and models to analyze situations or solve problems qualitatively and quantitatively.
<b>Learning Objective</b>	3.21: The student can use representations to describe how gene regulation influences cell products and function.

### Questions 8–10

An experiment to measure the rate of respiration in crickets and mice at 10°C and 25°C was performed using a respirometer, an apparatus that measures changes in gas volume. Respiration was measured in mL of O<sub>2</sub> consumed per gram of organism over several five-minute trials, and the following data were obtained.

Organism	Temperature (°C)	Average respiration (mL O <sub>2</sub> /g/min)
Mouse	10	0.0518
Mouse	25	0.0321
Cricket	10	0.0013
Cricket	25	0.0038

8. During aerobic cellular respiration, oxygen gas is consumed at the same rate as carbon dioxide gas is produced. In order to provide accurate volumetric measurements of oxygen gas consumption, the experimental setup should include which of the following?
- (A) A substance that removes carbon dioxide gas
  - (B) A plant to produce oxygen
  - (C) A glucose reserve
  - (D) A valve to release excess water

<b>Essential Knowledge</b>	2.A.2: Organisms capture and store free energy for use in biological processes. 2.D.1: All biological systems from cells and organisms to populations, communities, and ecosystems are affected by complex biotic and abiotic interactions involving exchange of matter and free energy.
<b>Science Practice</b>	6.2: The student can construct explanations of phenomena based on evidence produced through scientific practices.
<b>Learning Objective</b>	2.5: The student is able to construct explanations of the mechanisms and structural features of cells that allow organisms to capture, store, or use free energy.



9. According to the data, the mice at 10°C demonstrated greater oxygen consumption per gram of tissue than did the mice at 25°C. This is most likely explained by which of the following statements?
- (A) The mice at 10°C had a higher rate of ATP production than the mice at 25°C.
  - (B) The mice at 10°C had a lower metabolic rate than the mice at 25°C.
  - (C) The mice at 25°C weighed less than the mice at 10°C.
  - (D) The mice at 25°C were more active than the mice at 10°C.

<b>Essential Knowledge</b>	2.A.2: Organisms capture and store free energy for use in biological processes.
<b>Science Practice</b>	6.2: The student can construct explanations of phenomena based on evidence produced through scientific practices.
<b>Learning Objective</b>	2.5: The student is able to construct explanations of the mechanisms and structural features of cells that allow organisms to capture, store, or use free energy.

10. According to the data, the crickets at 25°C have greater oxygen consumption per gram of tissue than do the crickets at 10°C. This trend in oxygen consumption is the opposite of that in the mice. The difference in trends in oxygen consumption among crickets and mice is due to their
- (A) relative size
  - (B) mode of nutrition
  - (C) mode of internal temperature regulation
  - (D) mode of ATP production

<b>Essential Knowledge</b>	2.A.1: All living systems require constant input of free energy. 2.A.2: Organisms capture and store free energy for use in biological processes.
<b>Science Practice</b>	6.2: The student can construct explanations of phenomena based on evidence produced through scientific practices.
<b>Learning Objective</b>	2.1: The student is able to explain how biological systems use free energy based on empirical data that all organisms require constant energy input to maintain organization, to grow, and to reproduce.

11. Which of the following statements most directly supports the claim that different species of organisms use different metabolic strategies to meet their energy requirements for growth, reproduction, and homeostasis?
- (A) During cold periods pond-dwelling animals can increase the number of unsaturated fatty acids in their cell membranes while some plants make antifreeze proteins to prevent ice crystal formation in tissues.
  - (B) Bacteria lack introns while many eukaryotic genes contain many of these intervening sequences.
  - (C) Carnivores have more teeth that are specialized for ripping food while herbivores have more teeth that are specialized for grinding food.
  - (D) Plants generally use starch molecules for storage while animals use glycogen and fats for storage.

<b>Essential Knowledge</b>	2.A.1: All living systems require constant input of free energy.
<b>Science Practice</b>	6.1: The student can justify claims with evidence.
<b>Learning Objective</b>	2.2: The student is able to justify a scientific claim that free energy is required for living systems to maintain organization, to grow, or to reproduce, but that multiple strategies exist in different living systems.

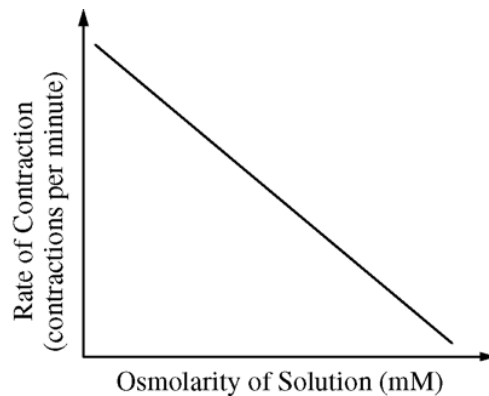

12. Paramecia are unicellular protists that have contractile vacuoles to remove excess intracellular water. In an experimental investigation, paramecia were placed in salt solutions of increasing osmolarity. The rate at which the contractile vacuole contracted to pump out excess water was determined and plotted against osmolarity of the solutions, as shown in the graph. Which of the following is the correct explanation for the data?
- (A) At higher osmolarity, lower rates of contraction are required because more salt diffuses into the paramecia.
  - (B) The contraction rate increases as the osmolarity decreases because the amount of water entering the paramecia by osmosis increases.
  - (C) The contractile vacuole is less efficient in solutions of high osmolarity because of the reduced amount of ATP produced from cellular respiration.
  - (D) In an isosmotic salt solution, there is no diffusion of water into or out of the paramecia, so the contraction rate is zero.

<b>Essential Knowledge</b>	2.B.2: Growth and dynamic homeostasis are maintained by the constant movement of molecules across membranes.
<b>Science Practice</b>	1.4: The student can use representations and models to analyze situations or solve problems qualitatively and quantitatively.
<b>Learning Objective</b>	2.12: The student is able to use representations and models to analyze situations or solve problems qualitatively and quantitatively to investigate whether dynamic homeostasis is maintained by the active movement of molecules across membranes.

### Questions 13–16

A student placed 20 tobacco seeds of the same species on moist paper towels in each of two petri dishes. Dish A was wrapped completely in an opaque cover to exclude all light. Dish B was not wrapped. The dishes were placed equidistant from a light source set to a cycle of 14 hours of light and 10 hours of dark. All other conditions were the same for both dishes. The dishes were examined after 7 days, and the opaque cover was permanently removed from dish A. Both dishes were returned to the light and examined again at 14 days. The following data were obtained.

	Dish A		Dish B	
	Day 7 Covered	Day 14 Uncovered	Day 7 Uncovered	Day 14 Uncovered
Germinated seeds	12	20	20	20
Green-leaved seedlings	0	14	15	15
Yellow-leaved seedlings	12	6	5	5
Mean stem length below first set of leaves	8 mm	9 mm	3 mm	3 mm

13. According to the results of this experiment, germination of tobacco seeds during the first week is
- (A) increased by exposure to light
  - (B) unaffected by light intensity
  - (C) prevented by paper towels
  - (D) accelerated in green-leaved seedlings

<b>Essential Knowledge</b>	2.D.1: All biological systems from cells and organisms to populations, communities, and ecosystems are affected by complex biotic and abiotic interactions involving exchange of matter and free energy.
<b>Science Practice</b>	5.1: The student can analyze data to identify patterns or relationships.
<b>Learning Objective</b>	2.24: The student is able to analyze data to identify possible patterns and relationships between a biotic or abiotic factor and a biological system (cells, organisms, populations, communities, or ecosystems).

14. The most probable cause for the difference in mean stem length between plants in dish A and plants in dish B is which of the following?
- (A) Shortening of cells in the stem in response to the lack of light
  - (B) Elongation of seedlings in response to the lack of light
  - (C) Enhancement of stem elongation by light
  - (D) Genetic differences between the seeds

<b>Essential Knowledge</b>	2.D.1: All biological systems from cells and organisms to populations, communities, and ecosystems are affected by complex biotic and abiotic interactions involving exchange of matter and free energy.
<b>Science Practice</b>	5.1: The student can analyze data to identify patterns or relationships.
<b>Learning Objective</b>	2.24: The student is able to analyze data to identify possible patterns and relationships between a biotic or abiotic factor and a biological system (cells, organisms, populations, communities, or ecosystems).

15. Which of the following best supports the hypothesis that the difference in leaf color is genetically controlled?
- (A) The number of yellow-leaved seedlings in dish A on day 7
  - (B) The number of germinated seeds in dish A on days 7 and 14
  - (C) The death of all the yellow-leaved seedlings
  - (D) The existence of yellow-leaved seedlings as well as green-leaved ones on day 14 in dish B

<b>Essential Knowledge</b>	3.C.1: Changes in genotype can result in changes in phenotype.
<b>Science Practice</b>	7.2: The student can connect concepts in and across domain(s) to generalize or extrapolate in and/or across enduring understandings and/or big ideas.
<b>Learning Objective</b>	3.26: The student is able to explain the connection between genetic variations in organisms and phenotypic variations in populations.

16. Additional observations were made on day 21, and no yellow-leaved seedlings were found alive in either dish. This is most likely because
- (A) yellow-leaved seedlings were unable to absorb water from the paper towels
  - (B) taller green-leaved seedlings blocked the light and prevented photosynthesis
  - (C) yellow-leaved seedlings were unable to convert light energy to chemical energy
  - (D) a higher rate of respiration in yellow-leaved seedlings depleted their stored nutrients

<b>Essential Knowledge</b>	2.D.1: All biological systems from cells and organisms to populations, communities, and ecosystems are affected by complex biotic and abiotic interactions involving exchange of matter and free energy.
<b>Science Practice</b>	7.2: The student can connect concepts in and across domain(s) to generalize or extrapolate in and/or across enduring understandings and/or big ideas.
<b>Learning Objective</b>	2.23: The student is able to design a plan for collecting data to show that all biological systems (cells, organisms, populations, communities, and ecosystems) are affected by complex biotic and abiotic interactions.

17. The endocrine system incorporates feedback mechanisms that maintain homeostasis. Which of the following demonstrates negative feedback by the endocrine system?
- (A) During labor, the fetus exerts pressure on the uterine wall, inducing the production of oxytocin, which stimulates uterine wall contraction. The contractions cause the fetus to further push on the wall, increasing the production of oxytocin.
  - (B) After a meal, blood glucose levels become elevated, stimulating beta cells of the pancreas to release insulin into the blood. Excess glucose is then converted to glycogen in the liver, reducing blood glucose levels.
  - (C) At high elevation, atmospheric oxygen is more scarce. In response to signals that oxygen is low, the brain decreases an individual's rate of respiration to compensate for the difference.
  - (D) A transcription factor binds to the regulatory region of a gene, blocking the binding of another transcription factor required for expression.

<b>Essential Knowledge</b>	2.C.1: Organisms use negative feedback mechanisms to maintain their internal environments and respond to external environmental changes.
<b>Science Practice</b>	7.2: The student can connect concepts in and across domain(s) to generalize or extrapolate in and/or across enduring understandings and/or big ideas.
<b>Learning Objective</b>	2.16: The student is able to connect how organisms use negative feedback to maintain their internal environments.

18. Five new species of bacteria were discovered in Antarctic ice core samples. The nucleotide (base) sequences of rRNA subunits were determined for the new species. The table below shows the number of nucleotide differences between the species.

**NUCLEOTIDE DIFFERENCES**

Species	1	2	3	4	5
1	--	3	19	18	27
2		--	19	18	26
3			--	1	27
4				--	27
5					--

Which of the following phylogenetic trees is most consistent with the data?

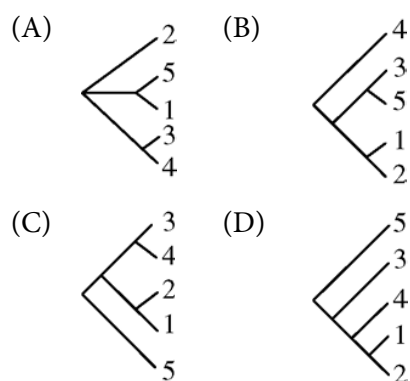

<b>Essential Knowledge</b>	1.B.2: Phylogenetic trees and cladograms are graphical representations (models) of evolutionary history that can be tested.
<b>Science Practice</b>	1.1: The student can create representations and models of natural or man-made phenomena and systems in the domain.
<b>Learning Objective</b>	1.19: The student is able create a phylogenetic tree or simple cladogram that correctly represents evolutionary history and speciation from a provided data set.



19. The first diagram below shows the levels of mRNA from two different genes (*bicoid* and *caudal*) at different positions along the anterior-posterior axis of a *Drosophila* egg immediately before fertilization. The second diagram shows the levels of the two corresponding proteins along the anterior-posterior axis shortly after fertilization.

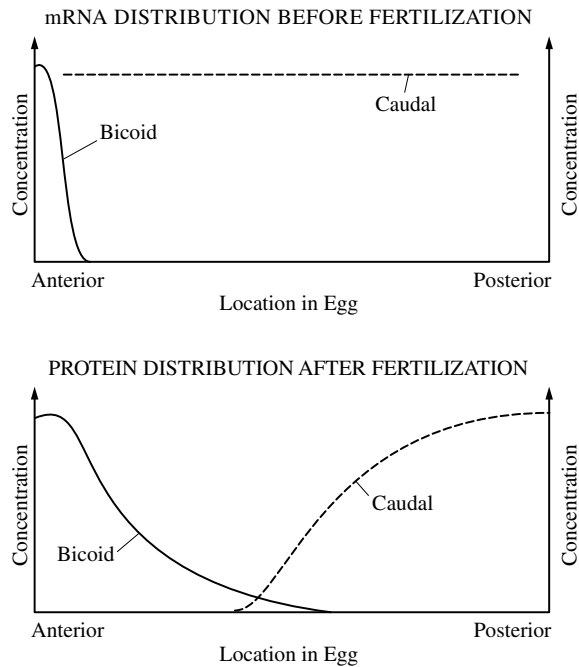

Which of the following conclusions is best supported by the data?

- (A) Bicoid protein inhibits translation of *caudal* mRNA.
- (B) Bicoid protein stabilizes *caudal* mRNA.
- (C) Translation of *bicoid* mRNA produces caudal protein.
- (D) Caudal protein stimulates development of anterior structures.

<b>Essential Knowledge</b>	2.E.1: Timing and coordination of specific events are necessary for the normal development of an organism, and these events are regulated by a variety of mechanisms.
<b>Science Practice</b>	1.4: The student can use representations and models to analyze situations or solve problems qualitatively and quantitatively.
<b>Learning Objective</b>	2.32: The student is able to use a graph or diagram to analyze situations or solve problems (quantitatively or qualitatively) that involve timing and coordination of events necessary for normal development in an organism.

20. Sickle-cell anemia results from a point mutation in the *HBB* gene. The mutation results in the replacement of an amino acid that has a hydrophilic R-group with an amino acid that has a hydrophobic R-group on the exterior of the hemoglobin protein. Such a mutation would most likely result in altered
- (A) properties of the molecule as a result of abnormal interactions between adjacent hemoglobin molecules
  - (B) DNA structure as a result of abnormal hydrogen bonding between nitrogenous bases
  - (C) fatty acid structure as a result of changes in ionic interactions between adjacent fatty acid chains
  - (D) protein secondary structure as a result of abnormal hydrophobic interactions between R-groups in the backbone of the protein

<b>Essential Knowledge</b>	4.A.1: The subcomponents of biological molecules and their sequence determine the properties of that molecule.
<b>Science Practice</b>	7.1: The student can connect phenomena and models across spatial and temporal scales.
<b>Learning Objective</b>	4.1: The student is able to explain the connection between the sequence and subcomponents of a biological polymer and its properties.

21. In a hypothetical population of beetles, there is a wide variety of color, matching the range of coloration of the tree trunks on which the beetles hide from predators. The graphs below illustrate four possible changes to the beetle population as a result of a change in the environment due to pollution that darkened the tree trunks.

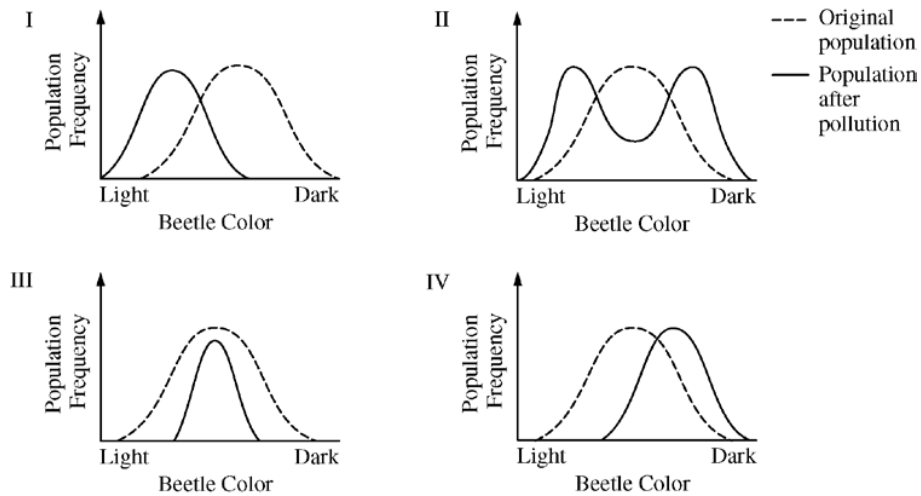

Which of the following includes the most likely change in the coloration of the beetle population after pollution and a correct rationale for the change?

- (A) The coloration range shifted toward more light-colored beetles, as in diagram I. The pollution helped the predators find the darkened tree trunks.
- (B) The coloration in the population split into two extremes, as in diagram II. Both the lighter-colored and the darker-colored beetles were able to hide on the darker tree trunks.
- (C) The coloration range became narrower, as in diagram III. The predators selected beetles at the color extremes.
- (D) The coloration in the population shifted toward more darker-colored beetles, as in diagram IV. The lighter-colored beetles were found more easily by the predators than were the darker-colored beetles.

<b>Essential Knowledge</b>	1.A.4: Biological evolution is supported by scientific evidence from many disciplines, including mathematics.
<b>Science Practice</b>	1.1: The student can create representations and models of natural or man-made phenomena and systems in the domain.
<b>Learning Objective</b>	1.13: The student is able to construct and/or justify mathematical models, diagrams, or simulations that represent processes of biological evolution.

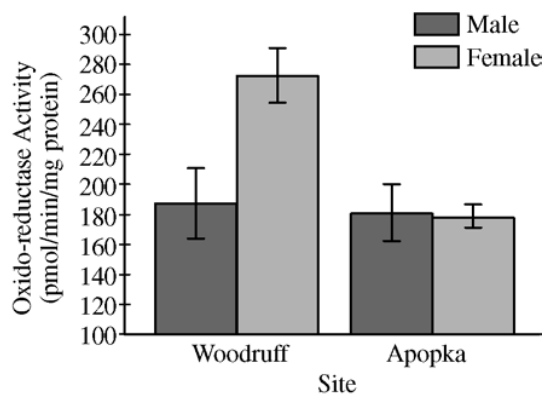

22. Testosterone oxido-reductase is a liver enzyme that regulates testosterone levels in alligators. One study compared testosterone oxido-reductase activity between male and female alligators from Lake Woodruff, a relatively pristine environment, and from Lake Apopka, an area that has suffered severe contamination. The graph above depicts the findings of that study.

The data in the graph best support which of the following claims?

- (A) Environmental contamination elevates total testosterone oxido-reductase activity in females.
- (B) Environmental contamination reduces total testosterone oxido-reductase activity in females.
- (C) Environmental contamination elevates total testosterone oxido-reductase activity in males.
- (D) Environmental contamination reduces total testosterone oxido-reductase activity in males.

<b>Essential Knowledge</b>	4.C.2: Environmental factors influence the expression of the genotype in an organism.
<b>Science Practice</b>	6.2: The student can construct explanations of phenomena based on evidence produced through scientific practices.
<b>Learning Objective</b>	4.23: The student is able to construct explanations of the influence of environmental factors on the phenotype of an organism.

23. An individual's humoral response to a particular antigen differs depending on whether or not the individual has been previously exposed to that antigen. Which of the following graphs properly represents the humoral immune response when an individual is exposed to the same antigen more than once?

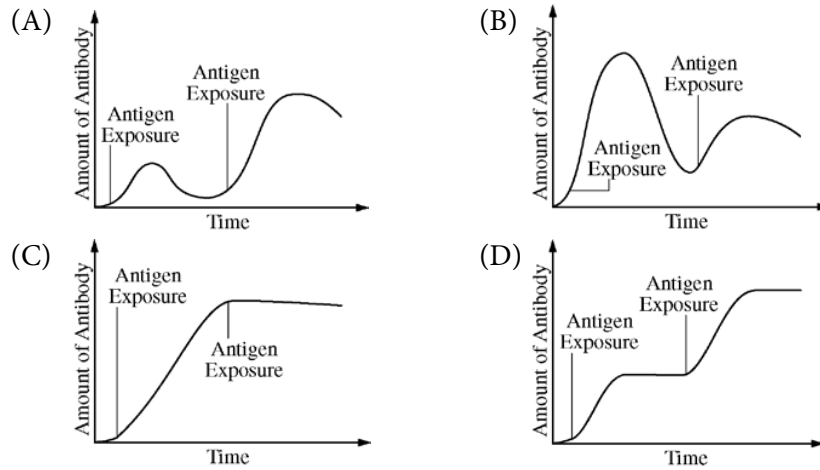

<b>Essential Knowledge</b>	2.D.4: Plants and animals have a variety of chemical defenses against infections that affect dynamic homeostasis.
<b>Science Practice</b>	1.2: The student can describe representations and models of natural or man-made phenomena and systems in the domain.
<b>Learning Objective</b>	2.29: The student can create representations and models to describe immune responses.

## Questions 24–28

In a transformation experiment, a sample of *E. coli* bacteria was mixed with a plasmid containing the gene for resistance to the antibiotic ampicillin ( $amp^r$ ). Plasmid was not added to a second sample. Samples were plated on nutrient agar plates, some of which were supplemented with the antibiotic ampicillin. The results of *E. coli* growth are summarized below. The shaded area represents extensive growth of bacteria; dots represent individual colonies of bacteria.

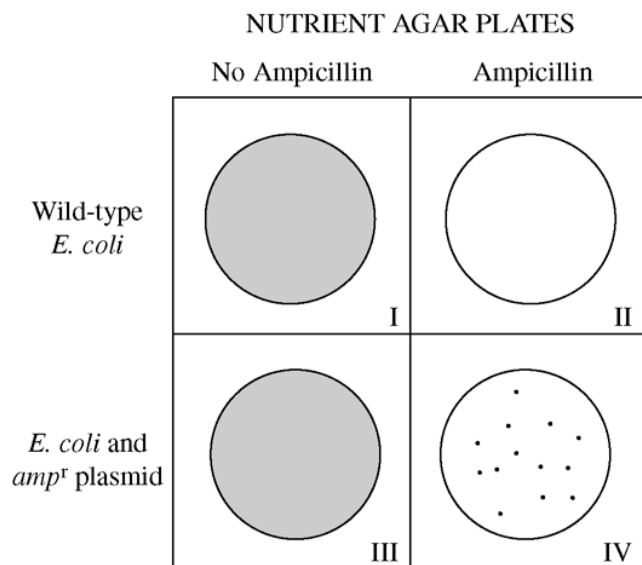

24. Plates that have only ampicillin-resistant bacteria growing include which of the following?
- (A) I only
- (B) III only
- (C) IV only
- (D) I and II

<b>Essential Knowledge</b>	3.C.2: Biological systems have multiple processes that increase genetic variation.
<b>Science Practice</b>	6.2: The student can construct explanations of phenomena based on evidence produced through scientific practices.
<b>Learning Objective</b>	3.28: The student is able to construct an explanation of the multiple processes that increase variation within a population.

25. Which of the following best explains why there is no growth on plate II?
- (A) The initial *E. coli* culture was not ampicillin-resistant.
  - (B) The transformation procedure killed the bacteria.
  - (C) Nutrient agar inhibits *E. coli* growth.
  - (D) The bacteria on the plate were transformed.

<b>Essential Knowledge</b>	3.C.2: Biological systems have multiple processes that increase genetic variation.
<b>Science Practice</b>	6.2: The student can construct explanations of phenomena based on evidence produced through scientific practices.
<b>Learning Objective</b>	3.28: The student is able to construct an explanation of the multiple processes that increase variation within a population.

26. Plates I and III were included in the experimental design in order to
- (A) demonstrate that the *E. coli* cultures were viable
  - (B) demonstrate that the plasmid can lose its *amp<sup>r</sup>* gene
  - (C) demonstrate that the plasmid is needed for *E. coli* growth
  - (D) prepare the *E. coli* for transformation

<b>Essential Knowledge</b>	3.C.2: Biological systems have multiple processes that increase genetic variation.
<b>Science Practice</b>	6.2: The student can construct explanations of phenomena based on evidence produced through scientific practices.
<b>Learning Objective</b>	3.28: The student is able to construct an explanation of the multiple processes that increase variation within a population.

27. Which of the following statements best explains why there are fewer colonies on plate IV than on plate III?
- (A) Plate IV is the positive control.
  - (B) Not all *E. coli* cells are successfully transformed.
  - (C) The bacteria on plate III did not mutate.
  - (D) The plasmid inhibits *E. coli* growth.

<b>Essential Knowledge</b>	3.C.2: Biological systems have multiple processes that increase genetic variation.
<b>Science Practice</b>	6.2: The student can construct explanations of phenomena based on evidence produced through scientific practices.
<b>Learning Objective</b>	3.28: The student is able to construct an explanation of the multiple processes that increase variation within a population.

28. In a second experiment, the plasmid contained the gene for human insulin as well as the *amp<sup>r</sup>* gene. Which of the following plates would have the highest percentage of bacteria that are expected to produce insulin?
- (A) I only
- (B) III only
- (C) IV only
- (D) I and III

<b>Essential Knowledge</b>	3.C.2: Biological systems have multiple processes that increase genetic variation.
<b>Science Practice</b>	6.2: The student can construct explanations of phenomena based on evidence produced through scientific practices.
<b>Learning Objective</b>	3.28: The student is able to construct an explanation of the multiple processes that increase variation within a population.

29. Experimental evidence shows that the process of glycolysis is present and virtually identical in organisms from all three domains, Archaea, Bacteria, and Eukarya. Which of the following hypotheses could be best supported by this evidence?
- (A) All organisms carry out glycolysis in mitochondria.
- (B) Glycolysis is a universal energy-releasing process and therefore suggests a common ancestor for all forms of life.
- (C) Across the three domains, all organisms depend solely on the process of anaerobic respiration for ATP production.
- (D) The presence of glycolysis as an energy-releasing process in all organisms suggests that convergent evolution occurred.

<b>Essential Knowledge</b>	1.B.1: Organisms share many conserved core processes and features that evolved and are widely distributed among organisms today.
<b>Science Practice</b>	7.2: The student can connect concepts in and across domain(s) to generalize or extrapolate in and/or across enduring understandings and/or big ideas.
<b>Learning Objective</b>	1.15: The student is able to describe specific examples of conserved core biological processes and features shared by all domains or within one domain of life, and how these shared, conserved core processes and features support the concept of common ancestry for all organisms.



30. A human kidney filters about 200 liters of blood each day. Approximately two liters of liquid and nutrient waste are excreted as urine. The remaining fluid and dissolved substances are reabsorbed and continue to circulate throughout the body. Antidiuretic hormone (ADH) is secreted in response to reduced plasma volume. ADH targets the collecting ducts in the kidney, stimulating the insertion of aquaporins into their plasma membranes and an increased reabsorption of water.

If ADH secretion is inhibited, which of the following would initially result?

- (A) The number of aquaporins would increase in response to the inhibition of ADH.
- (B) The person would decrease oral water intake to compensate for the inhibition of ADH.
- (C) Blood filtration would increase to compensate for the lack of aquaporins.
- (D) The person would produce greater amounts of dilute urine.

<b>Essential Knowledge</b>	3.D.3: Signal transduction pathways link signal reception with cellular response.
<b>Science Practice</b>	1.5: The student can re-express key elements of natural phenomena across multiple representations in the domain.
<b>Learning Objective</b>	3.36: The student is able to describe a model that expresses the key elements of signal transduction pathways by which a signal is converted to a cellular response.

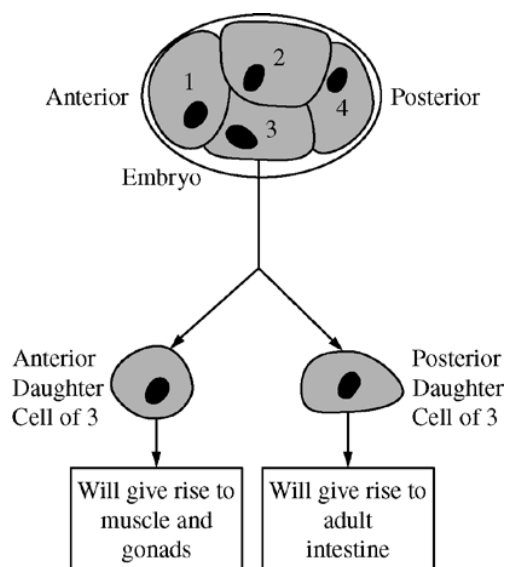

31. The diagram above shows a developing worm embryo at the four-cell stage. Experiments have shown that when cell 3 divides, the anterior daughter cell gives rise to muscle and gonads and the posterior daughter cell gives rise to the intestine. However, if the cells of the embryo are separated from one another early during the four-cell stage, no intestine will form. Other experiments have shown that if cell 3 and cell 4 are recombined after the initial separation, the posterior daughter cell of cell 3 will once again give rise to normal intestine. Which of the following is the most plausible explanation for these findings?
- (A) A cell surface protein on cell 4 signals cell 3 to induce formation of the worm's intestine.
- (B) The plasma membrane of cell 4 interacts with the plasma membrane of the posterior portion of cell 3, causing invaginations that become microvilli.
- (C) Cell 3 passes an electrical signal to cell 4, which induces differentiation in cell 4.
- (D) Cell 4 transfers genetic material to cell 3, which directs the development of intestinal cells.

<b>Essential Knowledge</b>	2.E.1: Timing and coordination of specific events are necessary for the normal development of an organism, and these events are regulated by a variety of mechanisms.
<b>Science Practice</b>	1.4: The student can use representations and models to analyze situations or solve problems qualitatively and quantitatively.
<b>Learning Objective</b>	2.32: The student is able to use a graph or diagram to analyze situations or solve problems (quantitatively or qualitatively) that involve timing and coordination of events necessary for normal development in an organism.

32. The tiny blue-eyed Mary flower is often one of the first flowers seen in the spring in some regions of the United States. The flower is normally blue, but sometimes a white or pink flower variation is found.

The following data were obtained after several crosses.

Parents	F <sub>1</sub>	F <sub>2</sub>
Blue × white	Blue	196 blue, 63 white
Blue × pink	Blue	149 blue, 52 pink
Pink × white	Blue	226 blue, 98 white, 77 pink

Which of the following statements best explains the data?

- (A) The appearance of blue in the F<sub>1</sub> generation of the pink and white cross demonstrates that flower color is not an inherited trait but is determined by the environment.
- (B) Flower color depends on stages of flower development, and young flowers are white, advancing to pink and then blue.
- (C) Since the F<sub>1</sub> and F<sub>2</sub> phenotypes of the pink and white cross do not fit the expected genotypic and phenotypic ratios, blue-eyed Mary must reproduce by vegetative propagation.
- (D) Flower color is an inherited trait, and the F<sub>1</sub> and F<sub>2</sub> phenotypes of the flowers arising from the pink and white cross can best be explained by another gene product that influences the phenotypic expression.

<b>Essential Knowledge</b>	3.A.2: In eukaryotes, heritable information is passed to the next generation via processes that include the cell cycle, mitosis, or meiosis plus fertilization.
<b>Science Practice</b>	5.3: The student can evaluate the evidence provided by data sets in relation to a particular scientific question.
<b>Learning Objective</b>	3.11: The student is able to evaluate evidence provided by data sets to support the claim that heritable information is passed from one generation to another generation through mitosis, or meiosis followed by fertilization.

## Questions 33–35

Both myoglobin and hemoglobin are proteins that bind reversibly with molecular oxygen. The graph below shows the oxygen-binding saturation of each protein at different concentrations of oxygen.

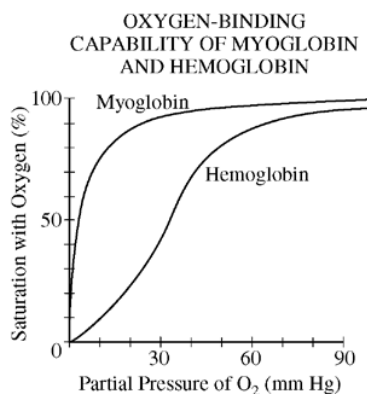

33. Which of the following statements is correct?
- (A) At 10 mm Hg partial pressure, hemoglobin binds oxygen but myoglobin does not.
  - (B) At 20 mm Hg partial pressure, myoglobin and hemoglobin bind oxygen in equal amounts.
  - (C) At 40 mm Hg partial pressure, myoglobin has a greater affinity for oxygen than hemoglobin has.
  - (D) At 80 mm Hg partial pressure, myoglobin binds twice as much oxygen as hemoglobin binds.

<b>Essential Knowledge</b>	4.B.1: Interactions between molecules affect their structure and function.
<b>Science Practice</b>	5.1: The student can analyze data to identify patterns or relationships.
<b>Learning Objective</b>	4.17: The student is able to analyze data to identify how molecular interactions affect structure and function.

34. Strenuous exercise lowers the blood pH, causing the curves for both hemoglobin and myoglobin to shift to the right. This shift results in
- (A) an unloading of O<sub>2</sub> at higher partial pressures
  - (B) an increase in the number of O<sub>2</sub>-binding sites
  - (C) the capture of more O<sub>2</sub> by hemoglobin
  - (D) the capture of more O<sub>2</sub> by myoglobin

<b>Essential Knowledge</b>	4.B.1: Interactions between molecules affect their structure and function.
<b>Science Practice</b>	5.1: The student can analyze data to identify patterns or relationships.
<b>Learning Objective</b>	4.17: The student is able to analyze data to identify how molecular interactions affect structure and function.

35. Which of the following best describes the physiological significance of the different oxygen-binding capabilities of hemoglobin and myoglobin?
- (A) They prevent muscles from depleting oxygen levels in the blood.
  - (B) They cause muscles to become anaerobic.
  - (C) They prevent glycogen depletion in muscles.
  - (D) They enhance movement of oxygen from the blood into the muscles.

<b>Essential Knowledge</b>	4.B.1: Interactions between molecules affect their structure and function.
<b>Science Practice</b>	5.1: The student can analyze data to identify patterns or relationships.
<b>Learning Objective</b>	4.17: The student is able to analyze data to identify how molecular interactions affect structure and function.

36. The chemical reaction for photosynthesis is

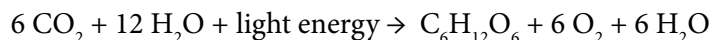

If the input water is labeled with a radioactive isotope of oxygen,  $^{18}\text{O}$ , then the oxygen gas released as the reaction proceeds is also labeled with  $^{18}\text{O}$ . Which of the following is the most likely explanation?

- (A) During the light reactions of photosynthesis, water is split, the hydrogen atoms combine with the  $\text{CO}_2$ , and oxygen gas is released.
- (B) During the light reactions of photosynthesis, water is split, removing electrons and protons, and oxygen gas is released.
- (C) During the Calvin cycle, water is split, regenerating NADPH from  $\text{NADP}^+$ , and oxygen gas is released.
- (D) During the Calvin cycle, water is split, the hydrogen atoms are added to intermediates of sugar synthesis, and oxygen gas is released.

<b>Essential Knowledge</b>	2.A.3: Organisms must exchange matter with the environment to grow, reproduce, and maintain organization.
<b>Science Practice</b>	4.1: The student can justify the selection of the kind of data needed to answer a particular scientific question.
<b>Learning Objective</b>	2.8: The student is able to justify the selection of data regarding the types of molecules that an animal, plant, or bacterium will take up as necessary building blocks and excrete as waste products.

37. A group of students summarized information on five great extinction events.

Mass Extinction	Time of Extinction	Organisms Greatly Reduced or Made Extinct
End of the Ordovician period	443 million years ago	Trilobites, brachiopods, echinoderms, and corals
End of the Devonian period	354 million years ago	Marine families on tropical reefs, corals, brachiopods, and bivalves
End of the Permian period	248 million years ago	Trilobites, mollusks, brachiopods, and many vertebrates
End of the Triassic period	206 million years ago	Mollusks, sponges, marine vertebrates, and large amphibians
End of the Cretaceous period	65 million years ago	Ammonites, dinosaurs, brachiopods, bivalves, and echinoderms

The students are sampling a site in search of fossils from the Devonian period. Based on the chart, which of the following would be the most reasonable plan for the students to follow?

- (A) Searching horizontal rock layers in any class of rock and trying to find those that contain the greatest number of fossils
- (B) Collecting fossils from rock layers deposited prior to the Permian period that contain some early vertebrate bones
- (C) Looking in sedimentary layers next to bodies of water in order to find marine fossils of bivalves and trilobites
- (D) Using relative dating techniques to determine the geological ages of the fossils found so they can calculate the rate of speciation of early organisms

<b>Essential Knowledge</b>	1.C.1: Speciation and extinction have occurred throughout the Earth's history.
<b>Science Practice</b>	4.2: The student can design a plan for collecting data to answer a particular scientific question.
<b>Learning Objective</b>	1.21: The student is able to design a plan for collecting data to investigate the scientific claim that speciation and extinction have occurred throughout Earth's history.

38. *Anabaena* is a simple multicellular photosynthetic cyanobacterium. In the absence of fixed nitrogen, certain newly developing cells along a filament express genes that code for nitrogen-fixing enzymes and become nonphotosynthetic heterocysts. The specialization is advantageous because some nitrogen-fixing enzymes function best in the absence of oxygen. Heterocysts do not carry out photosynthesis but instead provide adjacent cells with fixed nitrogen, in exchange receiving fixed carbon and reduced energy carriers.

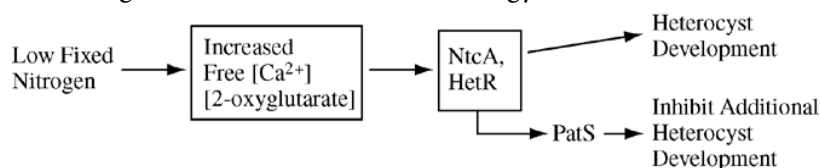

As shown in the diagram above, when there is low fixed nitrogen in the environment, an increase in the concentration of free calcium ions and 2-oxyglutarate stimulates the expression of genes that produce two transcription factors (NtcA and HetR) that promote the expression of genes responsible for heterocyst development. HetR also causes production of a signal, PatS, that prevents adjacent cells from developing as heterocysts.

Based on your understanding of the ways in which signal transmission mediates cell function, which of the following predictions is most consistent with the information given above?

- (A) In an environment with low fixed nitrogen, treating the *Anabaena* cells with a calcium-binding compound should prevent heterocyst differentiation.
- (B) A strain that overexpresses the *patS* gene should develop many more heterocysts in a low fixed nitrogen environment.
- (C) In an environment with abundant fixed nitrogen, free calcium levels should be high in all cells so that no heterocysts develop.
- (D) In environments with abundant fixed nitrogen, loss of the *hetR* gene should induce heterocyst development.

<b>Essential Knowledge</b>	4.A.3: Interactions between external stimuli and regulated gene expression result in specialization of cells, tissues, and organs.
<b>Science Practice</b>	1.3: The student can refine representations and models of natural or man-made phenomena and systems in the domain.
<b>Learning Objective</b>	4.7: The student is able to refine representations to illustrate how interactions between external stimuli and gene expression result in specialization of cells, tissues, and organs.



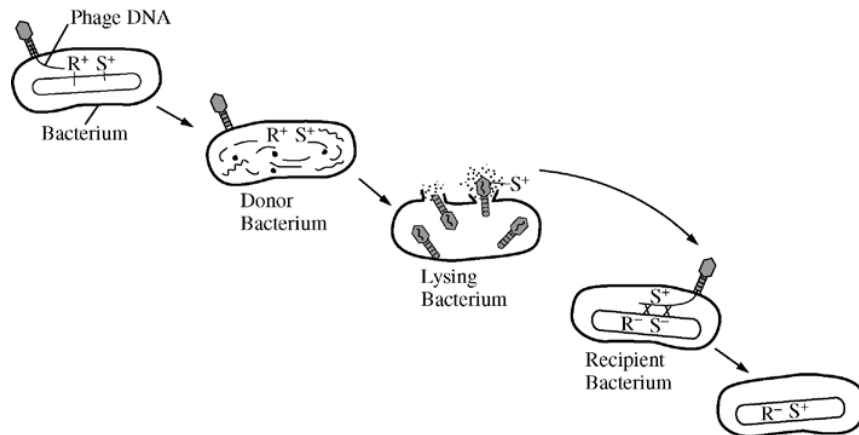

39. The figure above shows several steps in the process of bacteriophage transduction in bacteria. Which of the following explains how genetic variation in a population of bacteria results from this process?
- (A) Bacterial proteins transferred from the donor bacterium by the phage to the recipient bacterium recombine with genes on the recipient's chromosome.
  - (B) The recipient bacterium incorporates the transduced genetic material coding for phage proteins into its chromosome and synthesizes the corresponding proteins.
  - (C) The phage infection of the recipient bacterium and the introduction of DNA carried by the phage cause increased random point mutations of the bacterial chromosome.
  - (D) DNA of the recipient bacterial chromosome undergoes recombination with DNA introduced by the phage from the donor bacterium, leading to a change in the recipient's genotype.

<b>Essential Knowledge</b>	3.C.3: Viral replication results in genetic variation, and viral infection can introduce genetic variation into the hosts.
<b>Science Practice</b>	1.4: The student can use representations and models to analyze situations or solve problems qualitatively and quantitatively.
<b>Learning Objective</b>	3.30: The student is able to use representations and appropriate models to describe how viral replication introduces genetic variation in the viral population.

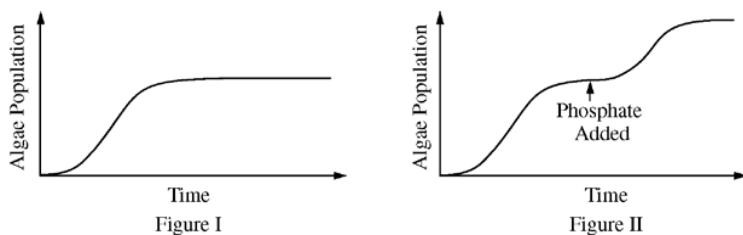

40. Figure I shows the growth of an algal species in a flask of sterilized pond water. If phosphate is added as indicated, the growth curve changes as shown in Figure II.

Which of the following is the best prediction of the algal growth if nitrate is added instead of phosphate?

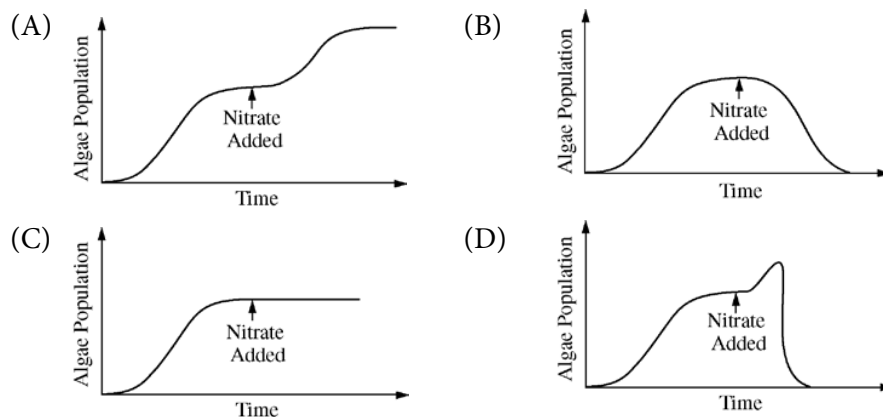

<b>Essential Knowledge</b>	2.D.1: All biological systems from cells and organisms to populations, communities, and ecosystems are affected by complex biotic and abiotic interactions involving exchange of matter and free energy.
<b>Science Practice</b>	3.2: The student can refine scientific questions.
<b>Learning Objective</b>	2.22: The student is able to refine scientific models and questions about the effect of complex biotic and abiotic interactions on all biological systems from cells and organisms to populations, communities, and ecosystems.

**Part B Directions:** Part B consists of questions requiring numeric answers. Calculate the correct answer for each question.

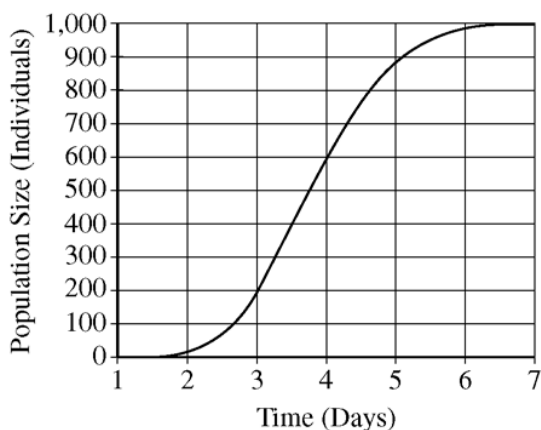

- Use the graph above to calculate the mean rate of population growth (individuals per day) between day 3 and day 5. Give your answer to the nearest whole number.

<b>Essential Knowledge</b>	1.A.1: Natural selection is a major mechanism of evolution.
<b>Science Practice</b>	2.2: The student can apply mathematical routines to quantities that describe natural phenomena.
<b>Learning Objective</b>	1.3: The student is able to apply mathematical methods to data from a real or simulated population to predict what will happen to the population in the future.

- In a certain species of flowering plant, the purple allele  $P$  is dominant to the yellow allele  $p$ .

A student performed a cross between a purple-flowered plant and a yellow-flowered plant. When planted, the 146 seeds that were produced from the cross matured into 87 plants with purple flowers and 59 plants with yellow flowers.

Calculate the chi-squared value for the null hypothesis that the purple-flowered parent was heterozygous for the flower-color gene. Give your answer to the nearest tenth.

<b>Essential Knowledge</b>	3.A.3: The chromosomal basis of inheritance provides an understanding of the pattern of passage (transmission) of genes from parent to offspring.
<b>Science Practice</b>	2.2: The student can apply mathematical routines to quantities that describe natural phenomena.
<b>Learning Objective</b>	3.14: The student is able to apply mathematical routines to determine Mendelian patterns of inheritance provided by data.